

Table II. Summary of Solvolysis Products from *cis*- and *trans*-VIII-OAc

VIII-OAc	Solvent	Temp, °C	Products
<i>cis</i>	80% Me ₂ CO	75	99.4% <i>cis</i> -VIII-OH, 0.6% <i>trans</i> -VIII-OH
<i>trans</i>	80% Me ₂ CO	100	83.4% <i>cis</i> -VIII-OH, 16.6% <i>trans</i> -VIII-OH
<i>cis</i>	MeOH	100	2.9% <i>cis</i> -VIII-OH, 97.9% VIII-OMe (98.9% <i>cis</i> :1.1% <i>trans</i>)
<i>trans</i>	MeOH	100	34.7% <i>trans</i> -VIII-OH, 65.3% VIII-OMe (98.7% <i>cis</i> :1.3% <i>trans</i>)

acid-catalyzed isomerization of the ether product during the quench, the observed product composition is in satisfactory agreement with that observed from kinetic control in acetate methanolysis. While the preference for *cis* stereospecificity in ionization and formation of covalent VIII derivatives is probably for stereoelectronic reasons, we are not yet prepared to discuss this in quantum-mechanical terms.⁷

Acknowledgment. We are grateful to Dr. Richard Leute and Mr. George Levy for assistance in some phases of the above research.

(7) It is pertinent that NaBH₄ reduction of VIII-ketone,⁸ mp 84–85°, gives 98.8% *cis*- and 1.2% *trans*-VIII-OH.

R. F. Childs, S. Winstein

Contribution No. 2143, Department of Chemistry
University of California, Los Angeles, California 90024

Received September 5, 1967

Degenerate Five-Carbon Scrambling in the 7-Norbornadienyl Cation¹

Sir:

In this communication we describe a novel degenerate rearrangement of the norbornadienyl cation I discovered during a search for "bridge flipping" by this species² (Ia ⇌ II ⇌ Ib).

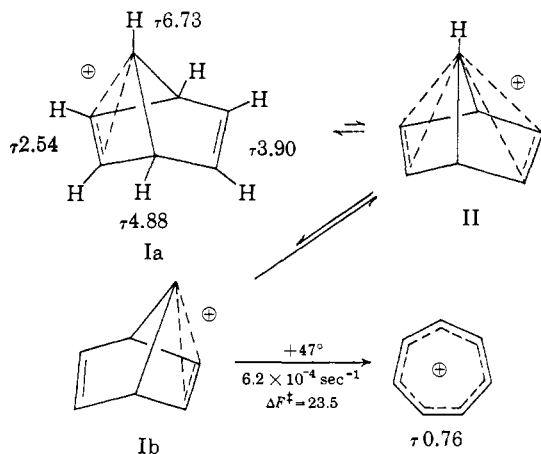

Extraction of 7-norbornadienol from pentane or CH₂Cl₂ into FSO₃H at -78° gave an FSO₃H solution of the 7-norbornadienyl cation I. Warming the solution to +45° caused no noticeable broadening of the nmr signals.² The ion decomposes at this temperature, as evidenced by the development of some broad,

(1) Research supported by the National Science Foundation.

(2) M. Brookhart, R. K. Lustgarten, and S. Winstein, *J. Am. Chem. Soc.*, **89**, 6352 (1967).

undetailed nmr signals, as well as a sharp signal at τ 0.76 for tropylium ion formed in *ca.* 25% yield. Despite very rapid decomposition, the nmr spectrum³ of ion I could be recorded at 77°. At this temperature the τ 2.54 signal for the "bound" vinyl protons was still sharp with the coupling pattern somewhat collapsed. However, the τ 3.90, 4.88, and 6.73 signals for "unbound" vinyl, bridgehead, and bridge protons were broadened, indicating the onset of an interesting degenerate rearrangement.

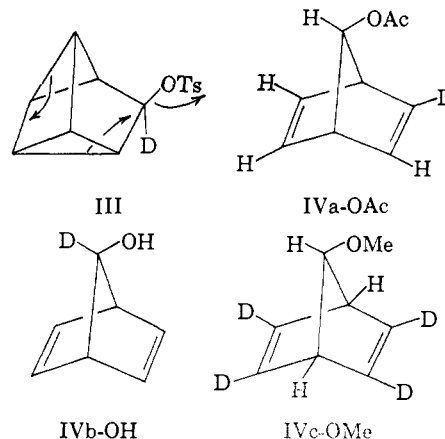

To study this rearrangement on a conventional rather than nmr time scale, labeled 7-norbornadienyl precursors were employed. These were IVa-OAc with a *syn*-vinyl deuterium obtained from acetolysis of 7-deuterioquadracyclol tosylate (III) via the Richey–Story rearrangement;⁴ IVb-OH with a 7-deuterium obtained from 7-deuterioquadracyclol; and IVc-OMe with 77% of 4-vinyl deuterium atoms obtained by base-catalyzed exchange⁵ of 7-norbornadienyl methyl ether with LiNDC₆H₁₁ in C₆H₁₁ND₂.

In FSO₃H at -73°, IVa-OAc displayed the four-signal spectrum of I with the intensity of the unbound vinyl signal only half as great as that for the bound vinyl (Ia). When the cation solution was warmed to -47°, a scrambling of the deuterium label was observed with a rate constant of $3 \times 10^{-4} \text{ sec}^{-1}$ (Table I). However, the vinyl proton peak intensities did not approach the 1:1 ratio expected for a bridge-flip phenomenon. Rather, the peak intensities approached a 2:1.6:1.6:0.8 ratio for the bound vinyl, unbound vinyl, bridgehead, and bridge protons, respectively (Ie). In other words, deuterium was scrambled to all positions *except* the bound vinyl! The same phenomenon was demonstrated with cations Ib and Ic from IVb and IVc, respectively (Table I). At -60° initially, both Ib and Ic exhibited the same relative peak intensities as their precursors, but, on warming to *ca.* -50°, these intensities approached the ratios expected for a five-carbon scrambling reaction (If and Ig, Table I).

Examination of the nmr signal intensities during scrambling of Ia, Ib, and Ic revealed that deuterium is incorporated sequentially at the different positions. Thus, in the case of Ia and Ic, deuterium is first in-

(3) All chemical shifts are based on CH₂Cl₂ as a secondary standard (τ 4.70).

(4) (a) H. G. Richey and N. C. Buckley, *J. Am. Chem. Soc.*, **85**, 3057 (1963); (b) P. R. Story and S. R. Fahrenholtz, *ibid.*, **86**, 527 (1964); **88**, 374 (1966).

(5) A. Streitwieser, Jr., and W. C. Langworthy, *ibid.*, **85**, 1757 (1963); A. Streitwieser, Jr., and J. H. Hammons, *Progr. Phys. Org. Chem.*, **3**, 73 (1965). We are grateful to C. Watts for assistance.

Table I. Rates and Free Energies of Activation of Degenerate Isomerizations of the 7-Norbornadienyl Cation

Cation			
Product			
Temp, °C	-47	-55	-50
$10^4 k, \text{sec}^{-1}$ ^a	3 ^a	1.7 ^c	2 ^b
$\Delta F^\ddagger, \text{kcal/mole}$	16.7	16.4	16.7

^a Evaluated graphically using $\ln [(H_\infty - H_0)/(H_\infty - H_t)] = kt$, with H_∞ equal to the equilibrium amount of protium. ^b In the unbound vinyl group. ^c At C₇.

incorporated into the bridgehead, then into the bridge position. With Ib, deuterium appears first at the bridgehead, then in the unbound vinyl group. Thus, the isomerization may be said to occur by a stepwise circumambulatory motion of five carbons of the framework of I with respect to the two which comprise the bound vinyl function. This description is supported by the relative line broadenings observed in the high-temperature nmr spectrum.⁶

The simplest specific mechanism which we can conceive for the 5-carbon degenerate rearrangement involves the ring contraction of I to a bicyclo[3.2.0]heptadienyl cation V by means of a 1,2 shift of a bound vinyl carbon atom from C₁ or C₄ to C₇ via a transition state such as IV, followed immediately by a ring expansion which leaves the same vinyl function bound to

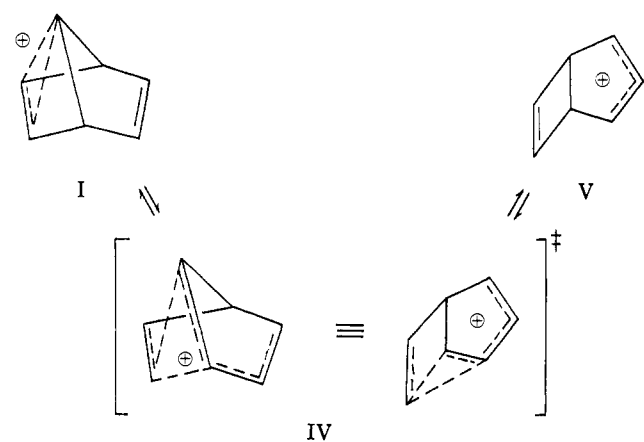

C₇. This is pictured by Ia \rightleftharpoons Va \rightleftharpoons Ic \rightleftharpoons Vb \rightleftharpoons Id, etc., which shows the bound vinyl group working its way around the five-membered ring defined by the five other carbon atoms in I. This mechanism is supported by the behavior of the *cis*- and *trans*-bicyclo[3.2.0]heptadienols^{7a} *cis*-VI-OH and *trans*-VI-OH in FSO₃H.

(6) The sequential rearrangement requires that the lifetime of the unbound vinyl protons be twice that of the C₇ and bridgehead protons and, indeed, the C₇ and bridgehead signals are broadened to twice the extent of the unbound vinyl protons. Based on line-width measurements, the rearrangement rate constant at +67° is ca. 40 sec⁻¹. From this rate constant and those in Table I, ΔH^\ddagger can be estimated as 14.5 \pm 2.0 kcal/mole.

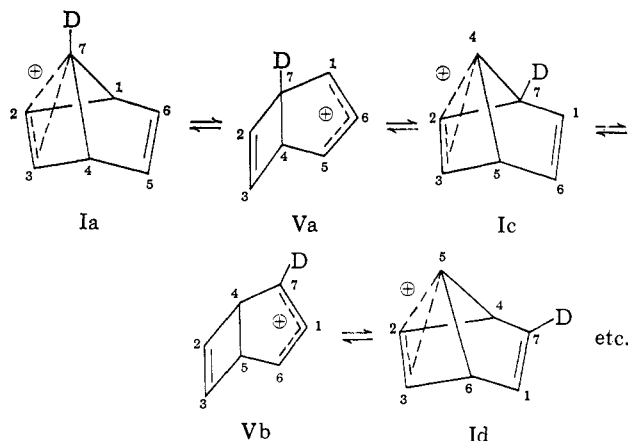

When either *cis*-VI-OH or *trans*-VI-OH was extracted into FSO₃H at -78°, and the carbonium ion solution was observed at -78° within 120 sec, the nmr spectrum of I was obtained with no trace of a signal for a [3.2.0] cation V. Most importantly, the α -deuterio *cis* and *trans* [3.2.0] alcohols both gave I with 2.0:1.5:1.5:1.0 ratios of signal intensities for bound vinyl, unbound vinyl, bridgehead, and bridge protons, respectively. In other words, 50% of the deuterium label appears at a bridgehead, and 50% in the unbound vinyl group. This result is in exact accord with a mechanism wherein the first formed [3.2.0] cation ring-expands to the [2.2.1] ion with either carbon of the cyclobutene vinyl function undergoing a 1,2 shift as the migrating vinyl group becomes the bound vinyl of I. The evidence is thus strongly in favor of the ring contraction-ring expansion mechanism for the degenerate five-carbon scrambling of I.^{8,9}

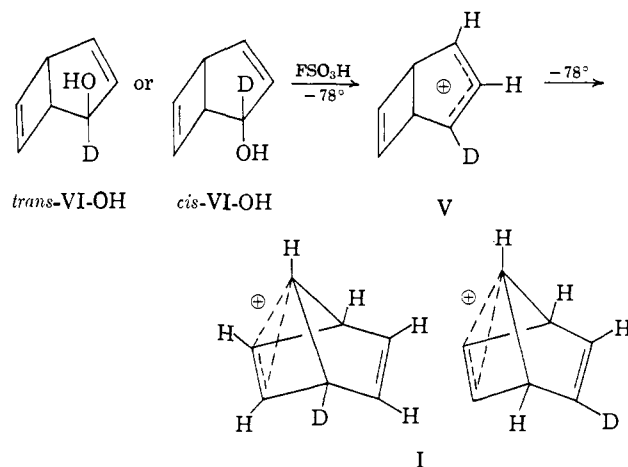

As regards the equilibrium between the [3.2.0] ion V and the [2.2.1] ion I, the latter is strongly favored. A

(7) (a) P. R. Story and S. R. Fahrenholtz, *J. Am. Chem. Soc.*, **87**, 1623 (1965); (b) P. R. Story, private communication of unpublished work.

(8) It is interesting that neither the ring contraction of I to V nor the ring expansion of V to I, which occur in the degenerate five-carbon scrambling of I in FSO₃H, where cations are very long-lived, compete with product formation in typical solvolyzing solvents where carbonium ion lifetime is very short. Thus, for example, ion Ia goes cleanly to IVa-OAc in AcOH.^{4b} Also, according to Story,^{7b} both *cis*-VI-Cl and *trans*-VI-Cl give only the [3.2.0]-type product in hydrolysis in aqueous acetone. On the other hand, the Richey-Story rearrangement of the 7-quadracycyl ion to norbornadienyl (I) does compete with product formation quite well in AcOH⁴ and even better in HCOOH.

(9) The [3.2.0] ion V, which appears to be an intermediate for the five-carbon scrambling of I, could conceivably be an intermediate for the tropylium ion formation. However, other mechanisms are conceivable as well, and this point is still far from clear.

minimum figure for the rate constant for $V \rightarrow I$ is 10^{-2} sec^{-1} at -78° , and the rate constant for $I \rightarrow V$ at this temperature may be estimated as $1.5 \times 10^{-6} \text{ sec}^{-1}$ from the available data. Thus, a minimum figure for the equilibrium constant for $V \rightleftharpoons I$ is 7000 at -78° .

(10) (a) National Institutes of Health Postdoctoral Fellow, 1966-1967; (b) National Institutes of Health Predoctoral Fellow, 1965-1967.

R. K. Lustgarten,^{10a} M. Brookhart,^{10b} S. Winstein
Contribution No. 2158, Department of Chemistry
University of California, Los Angeles, California 90024
Received September 18, 1967

Bridge Flipping and Rearrangement of Norbornadienyl and 7-Methylnorbornadienyl Cations¹

Sir:

The 7-norbornadienyl cation from anchimerically assisted ionization of 7-norbornadienyl derivatives was first studied solvolytically by Winstein and Ordroneau.² Of the possible nonclassical structures visualized by them, the unsymmetrical one represented by I³ can be chosen on the basis of the nmr spectrum of the ion observed by Story and Saunders.^{4a} A symmetrical structure represented by II³ was also envisioned, and this is clearly less stable than I. Even at $+45^\circ$, the vinyl proton signals for the "bound" and "unbound" vinyl groups in I are sharp,^{4a,5} thus showing that there is a substantial barrier to "bridge flipping" ($Ia \rightleftharpoons Ib$) via symmetrical II as a transition state ($>17 \text{ kcal/mole}$). On the other hand, extended Hückel calculations⁶ predict a relatively low value for this barrier (8 kcal; 0.35 eV). The magnitude of this barrier is one of the

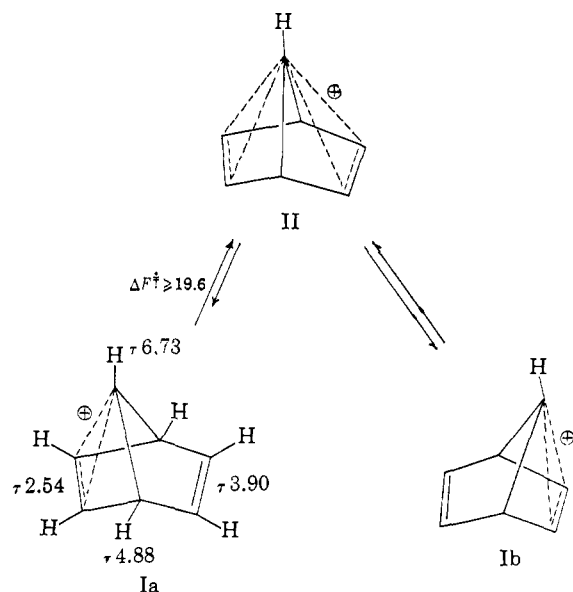

(1) Research supported by the National Science Foundation.

(2) S. Winstein and C. Ordroneau, *J. Am. Chem. Soc.*, **82**, 2084 (1960).

(3) These representations are employed for simplicity. Molecular orbital calculations suggest greater electron delocalization than is indicated: (a) R. J. Piccolini and S. Winstein, *Tetrahedron Suppl.*, **2**, 423 (1963); (b) W. G. Woods, Ph.D. Thesis, California Institute of Technology, 1957.

(4) P. R. Story and M. Saunders, *J. Am. Chem. Soc.*, **84**, 4876 (1962); P. R. Story, *et al.*, *ibid.*, **85**, 3630 (1963); (b) H. G. Richey, Jr., and R. K. Lustgarten, *ibid.*, **88**, 3136 (1966), have reported observation of I in FSO_3H .

(5) R. K. Lustgarten, M. Brookhart, and S. Winstein, *ibid.*, **89**, 6350 (1967).

(6) R. Hoffmann, *ibid.*, **86**, 1259 (1964).

subjects of this communication. Methyl substituent effects on the size of the barrier, and on nmr spectra as well, can be quite illuminating, and these are illustrated by means of the 7- and 2-methylnorbornadienyl cations.

It was possible to study the equilibration of bound and unbound vinyl groups in I by observing the labeled cation Ic derived from the precursor III-OMe as a result of degenerate five-carbon scrambling.⁵ Cation Ic has a deuterium atom at each bound vinyl position but only $2/5$ of a deuterium atom at each unbound vinyl position. At *ca.* 0° protium incorporation into the bound vinyl positions is indeed observed, the bound and unbound vinyl signals approaching equal intensities. At -2.5° , $k = 8 \times 10^{-4} \text{ sec}^{-1}$ and thus ΔF^\ddagger is 19.6 kcal/mole, some 3 kcal greater than ΔF^\ddagger for five-carbon scrambling.⁵

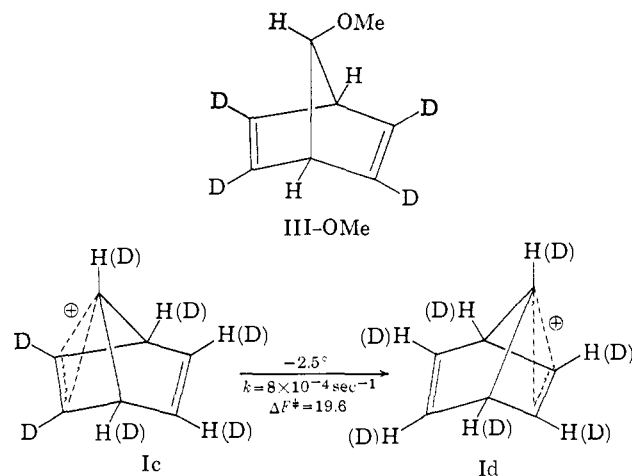

The value of 19.6 kcal/mole is actually a lower limit to the free-energy difference between the symmetrical (II) and unsymmetrical (I) structures of the 7-norbornadienyl cation. This is because bridge flipping is not the only possible mechanism for exchange of vinyl groups. For example, another plausible mechanism involves 1,2 shifts of an unbound vinyl carbon atom⁷ from C₁ to C₂, or C₄ to C₃. Such shifts, *e.g.*, $I \rightarrow Ie$, move the bound vinyl group around so as to scramble C₁, C₂, C₃, C₄, and C₇. Coupled with the more rapid degenerate five-carbon rearrangement reported previously,⁵ all seven carbon atoms of I become scrambled.⁸

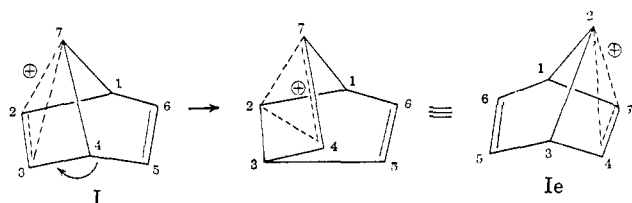

As the precursor to the 7-methyl cation V we employed alcohol IV. This was prepared by addition of methyl Grignard to quadricyclanone and subsequent isomerization of the 7-methylquadricyclanol to bicyclic IV with a correct C and H analysis and an appropriate nmr spectrum in CS_2 . Extraction of IV from CD_2Cl_2 into FSO_3H at -78° yielded an FSO_3H solution of V

(7) Any involvement of the "unbound" vinyl group in the electron delocalization of I³ would provide some predisposition to such a shift.

(8) Still another conceivable mechanism involves the kind of ring contraction occurring in the five-carbon scrambling⁵ but, instead of the bound vinyl migrating, it is now the less favored unbound vinyl. Ring contraction involving the unbound vinyl group, followed by the conventional ring expansion, results in an exchange of roles between bound and unbound vinyl groups.